

MATH 304
Linear Algebra

Lecture 4:
System with a parameter.
Applications of systems of linear equations.

System with a parameter.

$$\begin{cases} y + 3z = 0 \\ x + y - 2z = 0 \\ x + 2y + az = 0 \end{cases} \quad (a \in \mathbb{R})$$

The system is **homogeneous** (all right-hand sides are zeros). Therefore it is consistent ($x = y = z = 0$ is a solution).

Augmented matrix:
$$\left(\begin{array}{ccc|c} 0 & 1 & 3 & 0 \\ 1 & 1 & -2 & 0 \\ 1 & 2 & a & 0 \end{array} \right)$$

Since the 1st row cannot serve as a pivotal one, we interchange it with the 2nd row:

$$\left(\begin{array}{ccc|c} 0 & 1 & 3 & 0 \\ 1 & 1 & -2 & 0 \\ 1 & 2 & a & 0 \end{array} \right) \rightarrow \left(\begin{array}{ccc|c} 1 & 1 & -2 & 0 \\ 0 & 1 & 3 & 0 \\ 1 & 2 & a & 0 \end{array} \right)$$

Now we can start the elimination.

First subtract the 1st row from the 3rd row:

$$\left(\begin{array}{ccc|c} 1 & 1 & -2 & 0 \\ 0 & 1 & 3 & 0 \\ 1 & 2 & a & 0 \end{array} \right) \rightarrow \left(\begin{array}{ccc|c} 1 & 1 & -2 & 0 \\ 0 & 1 & 3 & 0 \\ 0 & 1 & a+2 & 0 \end{array} \right)$$

The 2nd row is our new pivotal row.

Subtract the 2nd row from the 3rd row:

$$\left(\begin{array}{ccc|c} 1 & 1 & -2 & 0 \\ 0 & 1 & 3 & 0 \\ 0 & 1 & a+2 & 0 \end{array} \right) \rightarrow \left(\begin{array}{ccc|c} 1 & 1 & -2 & 0 \\ 0 & 1 & 3 & 0 \\ 0 & 0 & a-1 & 0 \end{array} \right)$$

At this point row reduction splits into two cases.

Case 1: $a \neq 1$. In this case, multiply the 3rd row by $(a - 1)^{-1}$:

$$\left(\begin{array}{ccc|c} 1 & 1 & -2 & 0 \\ 0 & 1 & 3 & 0 \\ 0 & 0 & a-1 & 0 \end{array} \right) \rightarrow \left(\begin{array}{ccc|c} \boxed{1} & 1 & -2 & 0 \\ 0 & \boxed{1} & 3 & 0 \\ 0 & 0 & \boxed{1} & 0 \end{array} \right)$$

The matrix is converted into row echelon form.

We proceed towards reduced row echelon form.

Subtract 3 times the 3rd row from the 2nd row:

$$\left(\begin{array}{ccc|c} 1 & 1 & -2 & 0 \\ 0 & 1 & 3 & 0 \\ 0 & 0 & 1 & 0 \end{array} \right) \rightarrow \left(\begin{array}{ccc|c} 1 & 1 & -2 & 0 \\ 0 & 1 & 0 & 0 \\ 0 & 0 & 1 & 0 \end{array} \right)$$

Add 2 times the 3rd row to the 1st row:

$$\left(\begin{array}{ccc|c} 1 & 1 & -2 & 0 \\ 0 & 1 & 0 & 0 \\ 0 & 0 & 1 & 0 \end{array} \right) \rightarrow \left(\begin{array}{ccc|c} 1 & 1 & 0 & 0 \\ 0 & 1 & 0 & 0 \\ 0 & 0 & 1 & 0 \end{array} \right)$$

Finally, subtract the 2nd row from the 1st row:

$$\left(\begin{array}{ccc|c} 1 & 1 & 0 & 0 \\ 0 & 1 & 0 & 0 \\ 0 & 0 & 1 & 0 \end{array} \right) \rightarrow \left(\begin{array}{ccc|c} \boxed{1} & 0 & 0 & 0 \\ 0 & \boxed{1} & 0 & 0 \\ 0 & 0 & \boxed{1} & 0 \end{array} \right)$$

Thus $x = y = z = 0$ is the only solution.

Case 2: $a = 1$. In this case, the matrix is already in row echelon form:

$$\left(\begin{array}{ccc|c} \boxed{1} & 1 & -2 & 0 \\ 0 & \boxed{1} & 3 & 0 \\ 0 & 0 & 0 & 0 \end{array} \right)$$

To get reduced row echelon form, subtract the 2nd row from the 1st row:

$$\left(\begin{array}{ccc|c} 1 & 1 & -2 & 0 \\ 0 & 1 & 3 & 0 \\ 0 & 0 & 0 & 0 \end{array} \right) \rightarrow \left(\begin{array}{ccc|c} \boxed{1} & 0 & -5 & 0 \\ 0 & \boxed{1} & 3 & 0 \\ 0 & 0 & 0 & 0 \end{array} \right)$$

z is a free variable.

$$\begin{cases} x - 5z = 0 \\ y + 3z = 0 \end{cases} \iff \begin{cases} x = 5z \\ y = -3z \end{cases}$$

System of linear equations:

$$\begin{cases} y + 3z = 0 \\ x + y - 2z = 0 \\ x + 2y + az = 0 \end{cases}$$

Solution: If $a \neq 1$ then $(x, y, z) = (0, 0, 0)$;
if $a = 1$ then $(x, y, z) = (5t, -3t, t)$, $t \in \mathbb{R}$.

Applications of systems of linear equations

Problem 1. Find the point of intersection of the lines $x - y = -2$ and $2x + 3y = 6$ in \mathbb{R}^2 .

$$\begin{cases} x - y = -2 \\ 2x + 3y = 6 \end{cases}$$

Problem 2. Find the point of intersection of the planes $x - y = 2$, $2x - y - z = 3$, and $x + y + z = 6$ in \mathbb{R}^3 .

$$\begin{cases} x - y = 2 \\ 2x - y - z = 3 \\ x + y + z = 6 \end{cases}$$

Method of undetermined coefficients often involves solving systems of linear equations.

Problem 3. Find a quadratic polynomial $p(x)$ such that $p(1) = 4$, $p(2) = 3$, and $p(3) = 4$.

Suppose that $p(x) = ax^2 + bx + c$. Then
 $p(1) = a + b + c$, $p(2) = 4a + 2b + c$,
 $p(3) = 9a + 3b + c$.

$$\begin{cases} a + b + c = 4 \\ 4a + 2b + c = 3 \\ 9a + 3b + c = 4 \end{cases}$$

Method of undetermined coefficients often involves solving systems of linear equations.

Problem 3. Find a quadratic polynomial $p(x)$ such that $p(1) = 4$, $p(2) = 3$, and $p(3) = 4$.

Alternative choice of coefficients: $p(x) = \tilde{a} + \tilde{b}x + \tilde{c}x^2$.

Then $p(1) = \tilde{a} + \tilde{b} + \tilde{c}$, $p(2) = \tilde{a} + 2\tilde{b} + 4\tilde{c}$,
 $p(3) = \tilde{a} + 3\tilde{b} + 9\tilde{c}$.

$$\begin{cases} \tilde{a} + \tilde{b} + \tilde{c} = 4 \\ \tilde{a} + 2\tilde{b} + 4\tilde{c} = 3 \\ \tilde{a} + 3\tilde{b} + 9\tilde{c} = 4 \end{cases}$$

Problem 4. Evaluate $\int_0^1 \frac{x(x-3)}{(x-1)^2(x+2)} dx$.

To evaluate the integral, we need to decompose the rational function $R(x) = \frac{x(x-3)}{(x-1)^2(x+2)}$ into a sum of partial fractions:

$$\begin{aligned} R(x) &= \frac{a}{x-1} + \frac{b}{(x-1)^2} + \frac{c}{x+2} \\ &= \frac{a(x-1)(x+2) + b(x+2) + c(x-1)^2}{(x-1)^2(x+2)} \\ &= \frac{(a+c)x^2 + (a+b-2c)x + (-2a+2b+c)}{(x-1)^2(x+2)}. \end{aligned}$$

$$\begin{cases} a + c = 1 \\ a + b - 2c = -3 \\ -2a + 2b + c = 0 \end{cases}$$

Traffic flow

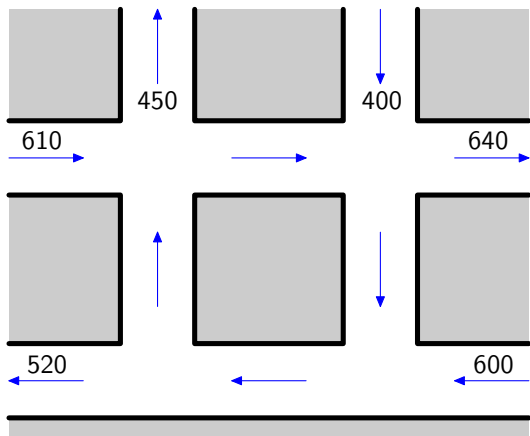

Problem. Determine the amount of traffic between each of the four intersections.

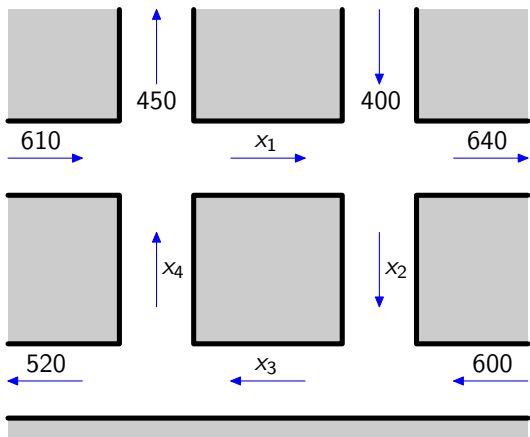

$$x_1 = ?, \quad x_2 = ?, \quad x_3 = ?, \quad x_4 = ?$$

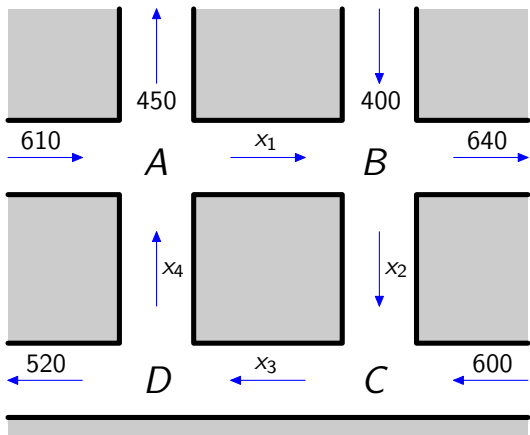

At each intersection, the incoming traffic has to match the outgoing traffic.

$$\text{Intersection } A: \quad x_4 + 610 = x_1 + 450$$

$$\text{Intersection } B: \quad x_1 + 400 = x_2 + 640$$

$$\text{Intersection } C: \quad x_2 + 600 = x_3$$

$$\text{Intersection } D: \quad x_3 = x_4 + 520$$

$$\begin{cases} x_4 + 610 = x_1 + 450 \\ x_1 + 400 = x_2 + 640 \\ x_2 + 600 = x_3 \\ x_3 = x_4 + 520 \end{cases}$$

$$\iff \begin{cases} -x_1 + x_4 = -160 \\ x_1 - x_2 = 240 \\ x_2 - x_3 = -600 \\ x_3 - x_4 = 520 \end{cases}$$

Electrical network

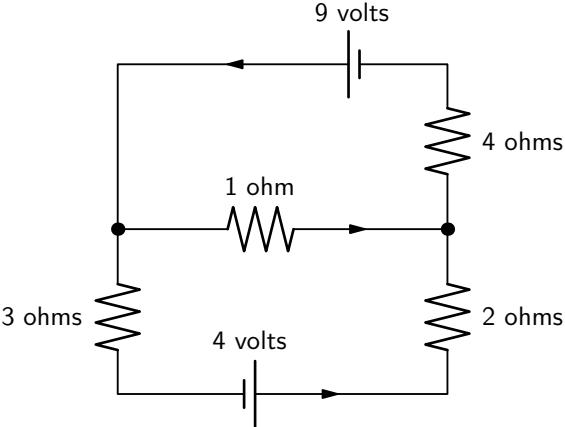

Problem. Determine the amount of current in each branch of the network.

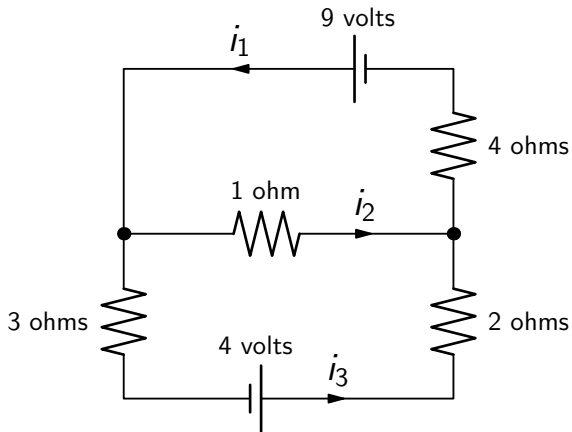

$$i_1 = ?, \quad i_2 = ?, \quad i_3 = ?$$

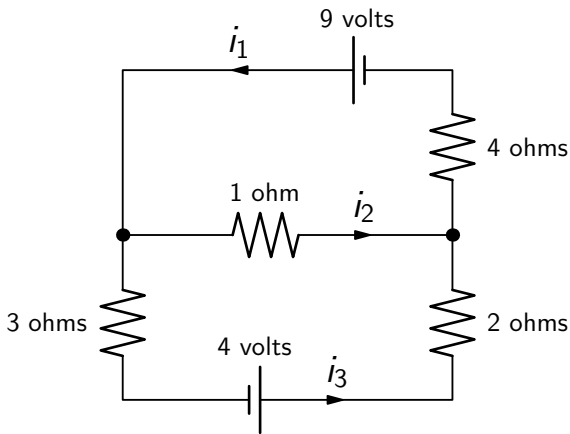

Kirchhof's law #1 (junction rule): at every node the sum of the incoming currents equals the sum of the outgoing currents.

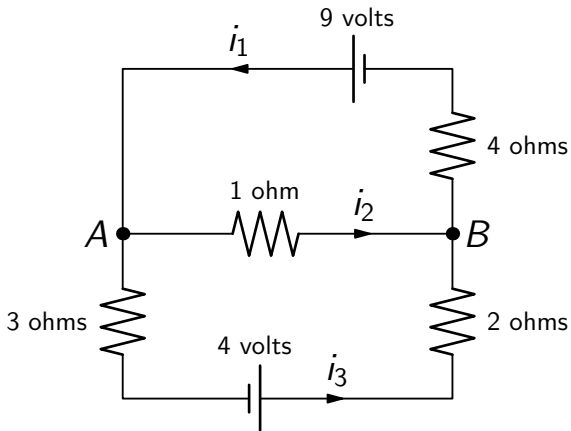

Node A: $i_1 = i_2 + i_3$

Node B: $i_2 + i_3 = i_1$

Electrical network

Kirchhof's law #2 (loop rule): around every loop the algebraic sum of all voltages is zero.

Ohm's law: for every resistor the voltage drop E , the current i , and the resistance R satisfy $E = iR$.

$$\text{Top loop:} \quad 9 - i_2 - 4i_1 = 0$$

$$\text{Bottom loop:} \quad 4 - 2i_3 + i_2 - 3i_3 = 0$$

$$\text{Big loop:} \quad 4 - 2i_3 - 4i_1 + 9 - 3i_3 = 0$$

Remark. The 3rd equation is the sum of the first two equations.

$$\begin{cases} i_1 = i_2 + i_3 \\ 9 - i_2 - 4i_1 = 0 \\ 4 - 2i_3 + i_2 - 3i_3 = 0 \end{cases}$$

$$\iff \begin{cases} i_1 - i_2 - i_3 = 0 \\ 4i_1 + i_2 = 9 \\ -i_2 + 5i_3 = 4 \end{cases}$$